



High Definition Wi-Fi Camera

LF1911



Parent Guide

This guide contains important information.
Please keep it for future reference.

**Visit our website leapfrog.com.au for more
information about products, downloads, resources
and more.**



**Scan the QR code
for more online
support:**



leapfrog.com.au/support

Important Safety Instructions

The applied nameplate is located at the bottom of the camera's base.

When using your equipment, basic safety precautions should always be followed to reduce the risk of fire, electric shock and injury, including the following:

1. Follow all warnings and instructions marked on the product.
2. Adult setup is required.
3. **CAUTION:** Do not install the camera at a height above 2 meters.
4. This product is intended as an aid. It is not a substitute for responsible and proper adult supervision and should not be used as such.
5. This product is not intended for use as a medical monitor.
6. Do not use this product near water, for example, near to a bath, sink, swimming pool or shower.
7. Use only the adaptors included with this product. Incorrect adaptor polarity or voltage can seriously damage the product.



Power adaptor information:



**Camera Output: 5V DC 1.5A;
VTech Telecommunications Ltd.;
Model: VT07EAU05150**

8. The power adaptors are intended to be correctly oriented in a vertical or floor mount position. The prongs are not designed to hold the plug in place if it is plugged into a ceiling, under-the-table or cabinet outlet.
9. For pluggable equipment, the socket-outlet shall be installed near the equipment and shall be easily accessible.
10. Unplug this product from the wall outlet before cleaning. Do not use liquid or aerosol cleaners. Use a damp cloth for cleaning. Do not cut off the power adaptors to replace them with other plugs, as this causes a hazardous situation.
11. Do not modify the power adaptors or replace with other adaptors, as this causes a hazardous situation.
12. Do not allow anything to rest on the power cords. Do not install this product where the cords may be walked on or crimped.
13. This product should be operated only from the type of power source indicated on the marking label. If you are not sure of the type of power supply in your home, consult your dealer or electricity supply provider
14. Do not overload wall outlets or use an extension cord.
15. Do not place this product on an unstable table, shelf, stand or other unstable surfaces.
16. This product should not be placed in any area where proper ventilation is not provided. Slots and openings in the back or bottom of this product are provided for ventilation. To protect them from overheating, these openings must not be blocked by placing the product on a soft surface such as a bed, sofa or rug. This product should never be placed near or over a radiator or heat source.

17. Never push objects of any kind into this product through the slots because they may touch dangerous voltage points or create a short circuit. Never spill liquid of any kind on the product.
18. To reduce the risk of electric shock, do not disassemble this product, but take it to an authorised service facility. Disassembling or removing parts of the product other than via the battery door may expose you to dangerous voltages or other risks. Incorrect reassembling can cause electric shock when the product is subsequently used.
19. You should test the sound reception every time you turn on the units or move one of the components.
20. Periodically examine all components for damage.
21. There is a very low risk of privacy loss when using certain electronic devices, such as baby monitors, cordless telephones, etc. **To protect your privacy, make sure the product has never been used before purchase, reset the baby monitor periodically by powering off and then powering on the units, and power off the baby monitor if you are not intending to use it for some time.**
22. Children should be supervised to ensure that they do not play with the product.
23. The product is not intended for use by persons (including children) with reduced physical, sensory or mental capabilities, or lack of experience and knowledge, unless they have been given supervision or instruction concerning use of the appliance by a person responsible for their safety.
24. The small parts of this monitor can be swallowed by babies or small children. Keep these parts out of reach of children.

SAVE THESE INSTRUCTIONS

Cautions

1. Use and store the product at a temperature between 0°C and 40°C.
2. Do not expose the product to extreme cold, heat or direct sunlight. Do not put the product close to a heating source.
3.  **Warning—Strangulation Hazard—** Children have STRANGLED in cords. Keep this cord out of the reach of children (more than 0.9m away). Do not remove warning label on the adaptor cord. 
4. Never place the camera inside the baby's cot or playpen. Never cover the camera with anything such as a towel or a blanket.
5. Other electronic products may cause interference with your baby monitor. Try installing your baby monitor as far away from these electronic devices as possible: wireless routers, radios, cellular telephones, intercoms, room monitors, televisions, personal computers, kitchen appliances and cordless telephones.

What's Included

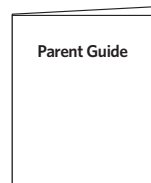
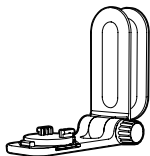
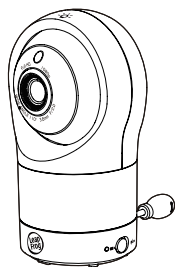

Connect and Power On the Camera

Notes:

- Use only the power adaptor supplied with this product.
- Make sure the camera is not connected to an electronically-controlled electric outlet.
- Connect the power adaptors in a vertical or floor mount position only. The adaptors' prongs are not designed to hold the weight of the camera, so do not connect them to any ceiling, under-the-table, or cabinet outlets. Otherwise, the adaptors may not properly connect to the outlets.
- Make sure the camera and the power adaptor cords are out of reach of children.

Connect the power adaptor to the camera and a power supply, then the camera powers on automatically.

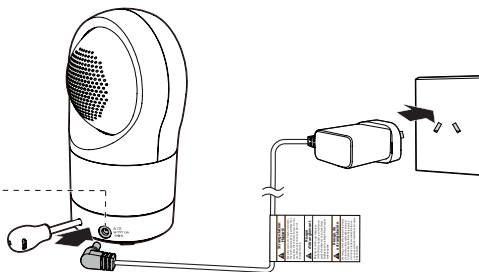
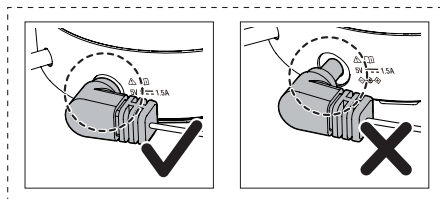

Overview

Camera

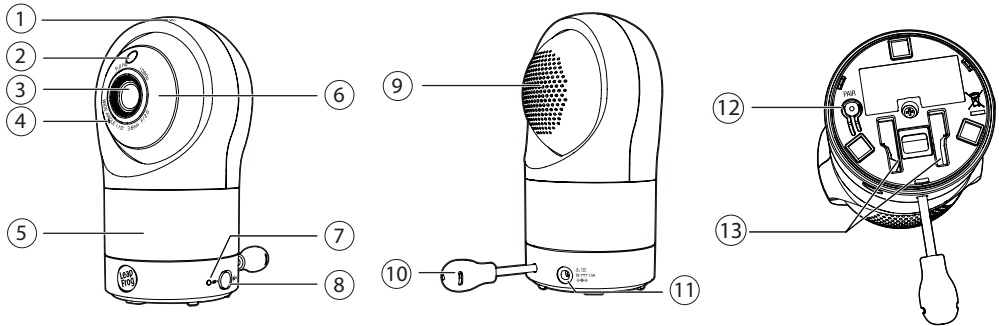

- 1** **Night light control key**
 - Tap to turn the night light on or off.
- 2** **Light sensor**
- 3** **Camera**
- 4** **Microphone**
- 5** **Night light**
- 6** **Infrared LEDs**
- 7** **Privacy LED light**
- 8** **Privacy key**
- 9** **Speaker**
- 10** **Temperature and humidity sensor**
- 11** **Power jack**
- 12** **PAIR / reset key**
 - Press and hold to pair the camera with your mobile devices.
- 13** **Wall mount holes**

Privacy Mode

Designed for extra peace of mind, turn on Privacy Mode for a moment of peace and quiet.

When the Privacy Mode is turned on, audio transmission and video monitoring will be disabled so motion recording, motion detection, and sound detection will be temporarily unavailable.

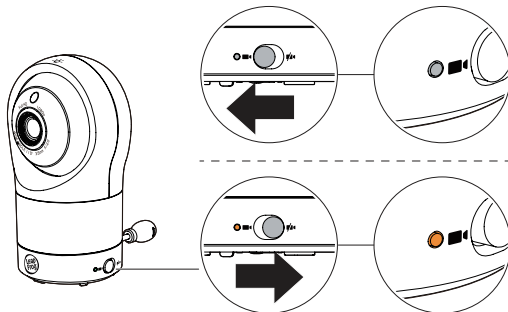

- Slide the **Privacy key** to to enter the privacy mode.
- Slide the **Privacy key** to to resume video monitoring.

Tip:

- The Privacy LED light turns orange when privacy mode is on.



Download LeapFrog Baby Care+ App

Start monitoring from anywhere.

Scan the QR code to download the free LeapFrog Baby Care+ mobile app, or search "LeapFrog Baby Care+" on Apple App Store or Google Play Store.



App Compatibility

- Android™ 6.0 or later
- iOS 12 or later.

After installing the LeapFrog Baby Care+ App...

- Sign up for an account
- Pair the camera with your mobile device
- Monitor your baby using a wide range of features



Pair the Camera with your Mobile Device

On LeapFrog Baby Care+ App

Before you start...

- Connect your mobile device to a 2.4GHz Wi-Fi network.
- Enable the Location Service of your mobile device for the purpose of camera setup.

With a 2.4GHz Wi-Fi network and enabled Location Service...

You can start to pair the camera with your own mobile device following the instructions in the app. Upon the successful pairing, you can hear and watch your baby via your mobile device.

Tips:

- Move the camera and the Wi-Fi router closer to each other in order to strengthen the network signal.
- It takes up around 1 minute to search and find the camera.

Position the Camera

1

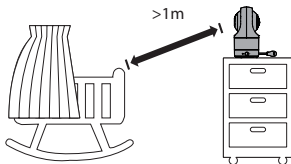

2

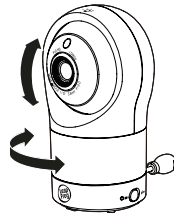



Use the App to pan and Tilt your camera.

Night Light

Want a softer hue from the camera's night light to relax your little one? You can control the brightness of its glow remotely from the LeapFrog Baby Care+ App, or directly on the camera.

Adjust the night light on the Camera

- Tap the **Night light control key**  located on the top of the camera to turn on/off the night light.
- Tap and hold (with the light turned on) the **Night light control key**  to adjust the night light brightness.

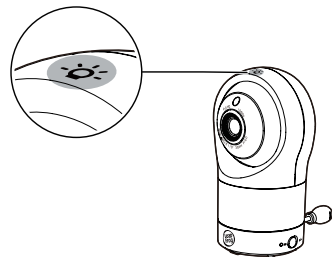

Note:

- If Auto Brightness has been pre-selected, any adjustment in night light brightness will automatically turn off Auto Brightness mode and switch to the fixed level of brightness.

Protect Your Privacy and Online Security

LeapFrog cares about your privacy and peace of mind. That's why we've put together a list of industry-recommended best practices to help keep your wireless connection private and your devices protected when online.

Ensure your wireless connection is secure

- Before installing a device, ensure your router's wireless signal is encrypted by selecting the "WPA2-PSK with AES" setting in your router's wireless security menu.

Change default settings

- Change your wireless router's default wireless network name (SSID) to something unique.
- Change default passwords to unique, strong passwords. A strong password:
 - Is at least 10 characters long.
 - Does not contain dictionary words or personal information.
 - Contains a mix of uppercase letters, lowercase letters, special characters and numbers.

Keep your devices up to date

- Download security patches from manufacturers as soon as they become available. This will ensure you always have the latest security updates.
- If the feature is available, enable automatic updates for future releases.

Disable Universal Plug and Play (UPnP) on your router

- UPnP enabled on a router can limit the effectiveness of your firewall by allowing other network devices to open inbound ports without any intervention or approval from you. A virus or other malware program could use this function to compromise security for the entire network.

For more information on wireless connections and protecting your data, please review the following resources from industry experts:

1. Federal Communications Commission: Wireless Connections and Bluetooth Security Tips – www.fcc.gov/consumers/guides/how-protect-yourself-online.
2. U.S. Department of Homeland Security: Before You Connect a New Computer to the Internet – www.us-cert.gov/hcas/tips/ST15-003.
3. Federal Trade Commission: Using IP Cameras Safely – <https://www.consumer.ftc.gov/articles/0382-using-ip-cameras-safely>.
4. Wi-Fi Alliance: Discover Wi-Fi Security – <http://www.wi-fi.org/discover-wi-fi/security>.

How the system works ?

Your home Wi-Fi network provides Internet connection to your camera so that you can monitor and control your camera whenever you are through the LeapFrog Baby Care+ App.

Your Wi-Fi router (not included) provides the Internet connectivity, which serves as a communicating channel.



**Mobile access or
Wi-Fi connection**

Test the Location for the Camera

If you plan to install your camera to a designated location, and will use your home Wi-Fi network to connect your mobile device, test whether your selected monitoring areas have good Wi-Fi signal strength. Adjust the direction and distance between your camera, mobile device and Wi-Fi router until you have identified a suitable location with good connection.

Note:

- Depending on surroundings and obstructing factors, such as the effect distance and internal walls have on signal strength, you may experience reduced Wi-Fi signal.

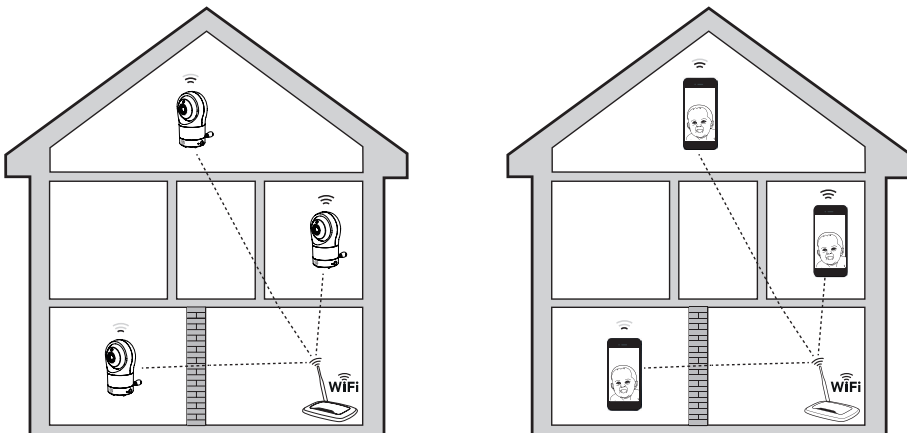

Mount the Camera (Optional)

Notes:

- Check for reception strength and the camera viewing angle before drilling the holes.
- The types of screws and wall plugs you need depend on the composition of the wall. You may need to purchase the screws and wall plugs separately to mount your camera.

1. Place the wall mount bracket on a wall and then use a pencil to mark the top and the bottom holes as shown. Remove the wall mount bracket and drill two holes in the wall (5.5mm drill bit).

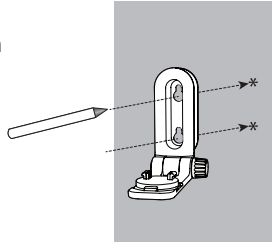

2. If you drill the holes into a stud, go to step 3.

- If you drill the holes into an object other than a stud, insert the wall plugs into the holes. Tap gently on the ends with a hammer until the wall plugs are flush with the wall.



3. Insert the screws into the holes and tighten the screws until only 6.5mm of the screws are exposed.

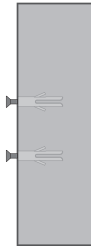

4. Place the camera on the wall mount bracket. Insert the mounting studs into the wall mount holes. Then, slide the camera forwards until it locks securely. Align the holes on the wall mount bracket with the screws on the wall, and slide the wall mount bracket down until it locks into place.

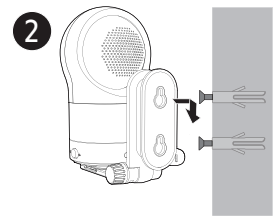
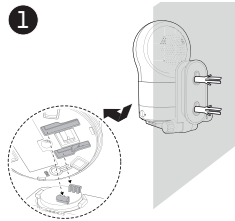

5. You can maximise your camera viewing angles by tilting the wall mount bracket. Hold the camera, and then rotate the knob in an anti-clockwise direction. This will loosen the joint of the wall mount bracket. Tilt your camera up or down to adjust to your preferred angle. Then, rotate the knob in a clockwise direction to tighten the joint and secure the angle.

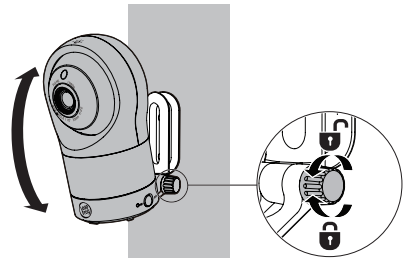

General product care

To keep this product working well and looking good, follow these guidelines:

- Avoid placing it near heating appliances and devices that generate electrical noise (for example, motors or fluorescent lamps).
- DO NOT expose it to direct sunlight or moisture.
- Avoid dropping the product or treating it roughly.
- Clean with a soft damp cloth.
- DO NOT immerse the camera in water and do not clean it under running water.
- DO NOT use cleaning spray or liquid cleaners.
- Make sure the camera is dry before you connect it to the mains again.

Disposal of batteries and product



The crossed-out wheellie bin symbols on products and batteries, or on their respective packaging, indicates they must not be disposed of in domestic waste as they contain substances that can be damaging to the environment and human health.



The chemical symbols Hg, Cd or Pb, where marked, indicate that the battery contains more than the specified value of mercury (Hg), cadmium (Cd) or lead (Pb) set out in Battery Directive (2006/66/EC).

The solid bar indicates that the product was placed on the market after 13th August, 2005.

Help protect the environment by disposing of your product or batteries responsibly.

Customer Service and Product Warranty

IMPORTANT

Please retain this booklet with your sales receipt as proof of the date of purchase.

Customer Service

If you require assistance in operating this product, please call the TechHelp Information Line on 1300 369 193 or contact VTech by e-mail at: tcpsupport_au@vtech.com.

Voluntary Product Enquiry

In addition to your Statutory Rights and subject to the conditions below, VTech warrants that this product will be free from any defect in materials or workmanship under conditions of normal use for a period of 24 months from date of purchase.

VTech does not warrant that the product will be free from defects if defects are caused by an accident, misuse, abuse, improper installation or operation, vermin infestations, lack of reasonable care, unauthorised modification, loss of parts, tampering or attempted repair by a person not authorised by VTech; or where the product has been damaged by lightning or a mains power surge. To make a claim under this Voluntary Product Warranty you must call the TechHelp Information Line on 1300 369 193 or contact VTech by e-mail at: tcpsupport_au@vtech.com where a Customer Service Representative will inform you of the product return process. You will need to ensure that:

- You provide proof of purchase;
- Your product is suitably packaged (original packaging is not required); and
- You have included all components from the original purchase.

For your records

Date of purchase: _____

Place of purchase: _____

Serial number: _____

For Voluntary Product Warranty purposes, proof of purchase is required so please keep your receipt.

The benefits conferred by this Voluntary Product Warranty are in addition to other rights and remedies that are available to you under law, which cannot be excluded. The processes for this Voluntary Product Warranty in no way limit your rights which arise as a result of your Statutory Rights.

This Voluntary Product Warranty is given by:

VTech Telecommunications (Australia) Pty Ltd ABN 70 136 672 627

Address: 24 Gilby Road, Mount Waverley 3149

IMPORTANT NOTE: THIS IS NOT A PRODUCT RETURN OR SERVICE ADDRESS - PLEASE CONTACT TECHHELP BY PHONE OR EMAIL FOR PRODUCT AND WARRANTY SUPPORT. NO LIABILITY WILL BE ACCEPTED BY VTECH FOR PRODUCTS RETURNED TO THIS ADDRESS UNDER THIS VOLUNTARY PRODUCT WARRANTY.

Phone number: 1300 369 193

Email address: tcpsupport_au@vtech.com

Statutory Rights

Our goods come with guarantees that cannot be excluded under the Australian Consumer Law. You are entitled to a replacement or refund for a major failure and compensation for any other reasonably foreseeable loss or damage. You are also entitled to have the goods repaired or replaced if the goods fail to be of acceptable quality and the failure does not amount to a major failure.

Customer Support



Find the answer to your questions. Get assisted at your own pace using our online Quick Start Guide, or contact Customer Support with your inquiries.



Scan the QR code to access the online Quick Start Guide or visit leapfrog.com.au/support.

Technical Specifications

| | |
|-------------------------|---|
| Technology | Wi-Fi 2.4GHz 802.11 b/g/n |
| Channels | 1 - 13 (2412 - 2472 MHz) |
| Internet Connection | Minimum Requirement: 1.5 Mbps @ 720p or 2.5 Mbps @ 1080p upload bandwidth per camera |
| Nominal effective range | Actual operating range may vary according to environmental conditions at the time of use. |
| Power requirements | Camera unit power adaptor: Output: 5V DC @ 1.5A |

Credits:

The Background Noise sound file was created by Caroline Ford, and is used under the Creative Commons license.
The Stream Noise sound file was created by Caroline Ford, and is used under the Creative Commons license.
The Crickets At Night sound file was created by Mike Koenig, and is used under the Creative Commons license.
The Heart Beat sound file was created by Zarabadeu, and is used under the Creative Commons license.



Specifications are subject to change without notice.
© 2023 LeapFrog Enterprises, Inc.
a subsidiary of VTech Holdings Limited.
All rights reserved. 09/23. LF1911_AU_QSG_V2