



Little Office Learning Center™



Parent's Guide

This guide contains important information. Please keep it for future reference.

91-009715-005 (US)

INTRODUCTION

Thank you for purchasing the **Little Office Learning Center™**. The table contains more than 27 touch points to engage your child in gross and fine motor play while learning about numbers, letters, colors, first words and more. The different features on the table help your child practice manipulating their fingers, from grasping to pinching, and from turning to batting. All of the learning content can be presented in both English and Spanish to expose your child to different languages.

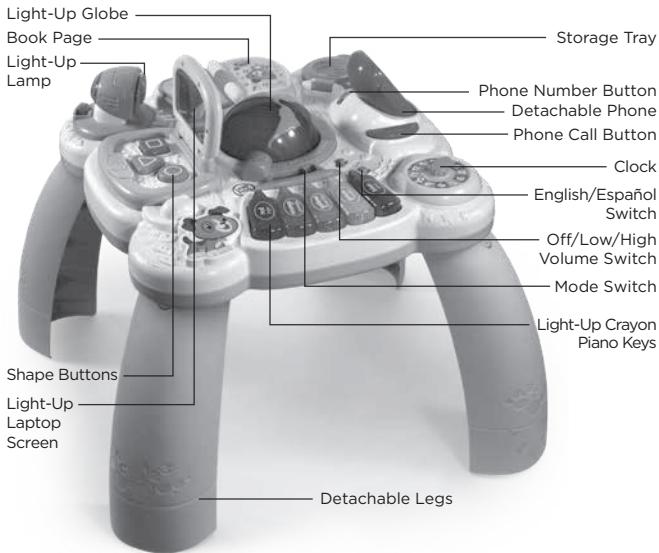

INCLUDED IN THIS PACKAGE

- One **Little Office Learning Center™**
- One detachable phone
- Four detachable legs
- One parent's guide

WARNING:

All packing materials such as tape, plastic sheets, packaging locks, removable tags, cable ties and packaging screws are not part of this toy and should be discarded for your child's safety.

NOTE:

Please keep this parent's guide as it contains important information.

ATTENTION :

Pour la sécurité de votre enfant, débarrassez-vous de tous les produits d'emballage tels que rubans adhésifs, feuilles de plastique, attaches, étiquettes et vis d'emballage. Ils ne font pas partie du jouet.

NOTE :

Il est conseillé de conserver ce guide des parents car il comporte des informations importantes.

Unlock the packaging locks:

- ① Rotate the packaging locks 90 degrees counterclockwise.
- ② Pull out the packaging locks and discard.

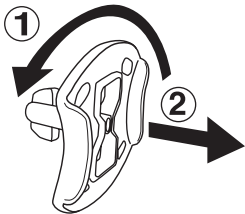

GETTING STARTED

BATTERY INSTALLATION

1. Make sure the unit is turned **OFF**.
2. Locate the battery cover on the bottom of the unit.
3. Use a screwdriver or a coin to loosen the screw and open the battery cover.
4. Install 2 new AA (AM-3/LR6) batteries into the battery box as illustrated. (The use of new alkaline batteries is recommended for maximum performance.)
5. Replace the battery cover and tighten the screw to secure.

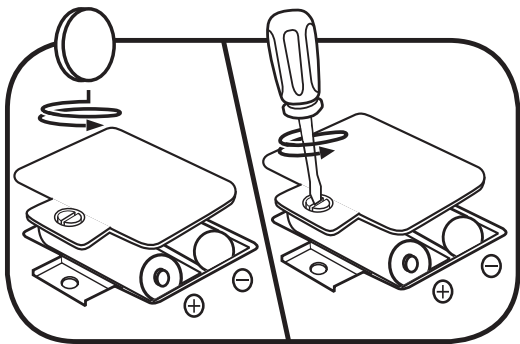

BATTERY NOTICE

- Use new alkaline batteries for maximum performance.
- Use only batteries of the same or equivalent type as recommended.
- Do not mix different types of batteries: alkaline, standard (carbon-zinc) or rechargeable, or new and used batteries.
- Do not use damaged batteries.
- Insert batteries with the correct polarity.
- Do not short-circuit the battery terminals.
- Remove exhausted batteries from the toy.
- Remove batteries during long periods of non-use.
- Do not dispose of batteries in fire.
- Do not charge non-rechargeable batteries.
- Remove rechargeable batteries from the toy before charging (if removable).
- Rechargeable batteries are only to be charged under adult supervision.

MISE EN GARDE

- Utiliser des piles alcalines neuves pour des performances maximales.
- Seules des piles du type recommandé doivent être utilisées.
- Ne pas mélanger différents types de piles ou d'accumulateurs, ne pas mélanger des piles ou des accumulateurs neufs avec des usagés.
- Ne pas utiliser des piles ou des accumulateurs endommagés.
- Mettre en place les piles ou les accumulateurs en respectant les polarités + et -.
- Ne pas mettre les bornes d'une pile ou d'un accumulateur en court-circuit (en reliant directement le + et le -).
- Enlever les piles ou les accumulateurs usagés du jouet.
- Retirer les piles ou les accumulateurs en cas de non-utilisation prolongée.
- Ne les jeter ni au feu ni dans la nature.
- Ne pas tenter de recharger des piles non rechargeables.
- Enlever les accumulateurs du jouet pour les recharger.
- Les accumulateurs ne doivent être chargés que sous la surveillance d'un adulte.

ASSEMBLY

With the **Little Office Learning Center™** safety comes first. To ensure your child's safety, adult assembly is required. Use the **Little Office Learning Center™** as a floor toy (without legs) for infants. Use as an activity table only when child is able to stand steadily. As with all toys for this age group, adult supervision is recommended.

To Attach the Legs:

1. Place tabletop on the floor with the bottom facing up, as shown.
2. With the smooth side of each leg facing out, insert one table leg into each corner of the table and snap securely into place.

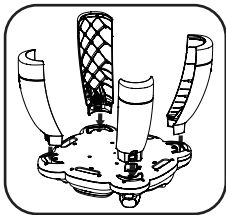

To Remove the Legs:

1. Place the tabletop on the floor with the bottom facing up, as shown.
2. Press the button on the table leg close to the tabletop and pull the leg out.

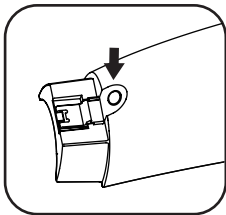

PRODUCT FEATURES

1. Off/Low/High Volume Switch

To turn the unit **ON**, slide the **Off/Low/High Volume Switch** to the **Low Volume**  or the **High Volume**  position.

To turn the unit **OFF**, slide the **Off/Low/High Volume Switch** to the **OFF**  position.



2. English/Español Switch

Slide the **English/Español Switch** to select the desired language.



3. Mode Switch

Move the **Mode Switch** to any position to play one of three modes: Explore Mode, Learn Mode or Music Mode.



4. Light-Up Globe

Spin the **Light-Up Globe** to explore music and greetings from around the world and hear phrases with light-up color effects.



5. Light-Up Crayon Piano Keys

Press the **Light-Up Crayon Piano Keys** to hear color names or musical notes. In Learn Mode, occasionally Scout will ask you to look for another feature on the table in that color to practice listening comprehension.



6. Clock

Rotate the **Clock** hand to hear times of day, daily routines, fun clock sounds and music.



7. Detachable Phone

Pick up the **Detachable Phone** and shake it to rattle the beads. Press the number pad or call button on the table for role-play fun.



8. Storage Tray

Flip the **Storage Tray** lid open and closed to practice fine motor skills. Place items in the storage tray for hide and reveal fun.



9. Book Page

Turn the **Book Page** to hear learning songs about the alphabet and emotions, melodies and phrases.



10. Light-Up Lamp Switch

Slide the **Light-Up Lamp Switch** to turn the lamp on and off and hear opposites, phrases and fun musical sounds.

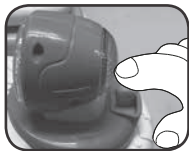

11. Light-Up Laptop Screen and Shape Buttons

Press the three **Shape Buttons** to light-up and reveal hidden animal friends in the mirrored screen and hear shape, color and animal names.



ACTIVITIES

1. Explore Mode

Play with more than 27 touch points to hear first words, simple phrases and sounds, the ABC Song and songs about emotions.

2. Learn Mode

Includes greetings from around the world, daily routines, phone pretend play and longer phrases to practice listening skills.

3. Music Mode

Spin the **Light-Up Globe** to hear more than 10 melodies from around the world. Press the **Light-Up Crayon Piano Keys** to hear musical sounds or press the **Shape Buttons** to hear three drum sounds. All touches play musical short tunes or fun sounds for cause & effect creative play.

4. Language Play

Slide the **English/Español Switch** to hear the directions, dialogue and songs in English or Spanish.

5. Floor Play

For children that are not developmentally ready to stand up yet, play with the toy on the floor without the legs attached.

6. Standing Play

For children who are starting to pull themselves up to stand, play with the toy with the legs attached. As the child plays with the features on the toy, it encourages them to cruise around the table to help prepare them to start walking.

CARE & MAINTENANCE

1. Keep the unit clean by wiping it with a slightly damp cloth.
2. Keep the unit out of direct sunlight and away from direct heat sources.
3. Remove the batteries when the unit is not in use for an extended period of time.
4. Do not drop the unit on a hard surface and do not expose the unit to excess moisture.

TROUBLESHOOTING

If for some reason the program/activity stops working or the unit can't be turned on again, then please follow these steps:

1. Turn the unit **OFF**.
2. Interrupt the power supply by removing the batteries.
3. Let the unit stand for a few minutes, then replace the batteries.
4. Turn the unit back **ON**. The unit will now be ready to play again.
5. If the unit does not work, replace with an entire set of new batteries.

IMPORTANT NOTE:

If the problem persists, please call our Consumer Services Department at **1-800-701-5327** in the U.S. or email support@leapfrog.com. Creating and developing LeapFrog® products is accompanied by a responsibility that we take very seriously. We make every effort to ensure the accuracy of the information, which forms the value of our products. However, errors sometimes can occur. It is important for you to know that we stand behind our products and encourage you to contact us with any problems and/or suggestions you might have. A service representative will be happy to help you.

Environmental Phenomena

The unit may malfunction if subjected to radio-frequency interference. It should revert to normal operation when the interference stops. If not, it may become necessary to turn the power **OFF** and back **ON**, or remove and reinstall the batteries. In the unlikely event of an electrostatic discharge, the unit may malfunction and lose memory, requiring the user to reset the device by removing and reinstalling the batteries.

Impact de l'environnement

Une défaillance de fonctionnement de l'appareil peut survenir s'il est sujet à des interférences avec les fréquences radioélectriques. Le fonctionnement normal de l'appareil devrait reprendre avec l'arrêt des interférences. Si ce n'est pas le cas, il peut s'avérer nécessaire d'éteindre et rallumer l'appareil ou de retirer et réinstaller les piles. Dans l'éventualité peu probable d'une décharge électrostatique, un mauvais fonctionnement et une perte de mémoire de l'appareil peuvent se produire. L'utilisateur doit alors retirer et réinstaller les piles pour réinitialiser l'appareil.

NOTE:

This equipment has been tested and found to comply with the limits for a Class B digital device, pursuant to Part 15 of the FCC Rules. These limits are designed to provide reasonable protection against harmful interference in a residential installation. This equipment generates, uses and can radiate radio frequency energy and, if not installed and used in accordance with the instructions, may cause harmful interference to radio communications. However, there is no guarantee that interference will not occur in a particular installation. If this equipment does cause harmful interference to radio or television reception, which can be determined by turning the equipment off and on, the user is encouraged to try to correct the interference by one or more of the following measures:

- Reorient or relocate the receiving antenna.
- Increase the separation between the equipment and receiver.
- Connect the equipment into an outlet on a circuit different from that to which the receiver is connected.
- Consult the dealer or an experienced radio/TV technician for help.

THIS DEVICE COMPLIES WITH PART 15 OF THE FCC RULES. OPERATION IS SUBJECT TO THE FOLLOWING TWO CONDITIONS: (1) THIS DEVICE MAY NOT CAUSE HARMFUL INTERFERENCE, AND (2) THIS DEVICE MUST ACCEPT ANY INTERFERENCE RECEIVED, INCLUDING INTERFERENCE THAT MAY CAUSE UNDESIRE OPERATION.

CAN ICES-3 (B)/NMB-3(B)

Caution: Changes or modifications not expressly approved by the party responsible for compliance could void the user's authority to operate the equipment.

Supplier's Declaration of Conformity

Trade Name:	LeapFrog®
Model:	6043
Product name:	Little Office Learning Center™
Responsible Party:	LeapFrog Enterprises, Inc.
Address:	6401 Hollis Street, Suite 100, Emeryville, CA 94608
Website:	leapfrog.com



**CLASS 1
LED PRODUCT**



***Visit our website for more
information about our products,
downloads, resources and more.***

leapfrog.com

***Read our complete warranty policy online at
leapfrog.com/warranty.***

LeapFrog Enterprises, Inc.
A subsidiary of VTech Holdings Limited.
TM & © 2018 LeapFrog Enterprises, Inc.
All rights reserved.
91-009715-005 