



Lettersaurus™



Parent's Guide

This guide contains important information. Please keep it for future reference.

91-003652-000 (US)

INTRODUCTION

Thank you for purchasing **Lettersaurus™**! This adorable alphabet dinosaur has colorful letter buttons on his back for kids to explore letter names and letter sounds. Press the dino or footprint button to hear friendly phrases or add sounds to a jungle beat. Spin the tail wheel to learn numbers and play a counting song. For more music, press the light-up star button to play three upbeat songs. Pull the dinosaur to watch his head turn side-to-side as he wobbles along.

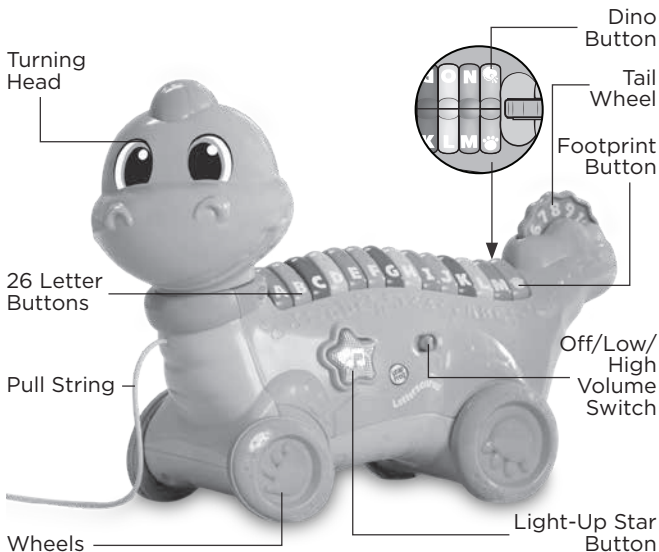

INCLUDED IN THIS PACKAGE

- One **Lettersaurus™**
- One parent's guide

WARNING:

All packing materials such as tape, plastic sheets, packaging locks, removable tags, cable ties and packaging screws are not part of this toy, and should be discarded for your child's safety.

NOTE:

Please keep this parent's guide as it contains important information.

ATTENTION :

Pour la sécurité de votre enfant, débarrassez-vous de tous les produits d'emballage tels que rubans adhésifs, feuilles de plastique, attaches, étiquettes et vis d'emballage. Ils ne font pas partie du jouet.

NOTE :

Il est conseillé de conserver ce guide des parents car il comporte des informations importantes.

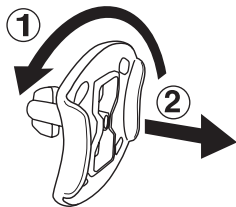

Unlock the packaging locks:

- ① Rotate the packaging locks 90 degrees counterclockwise.
- ② Pull out the packaging locks and discard.

GETTING STARTED

BATTERY INSTALLATION

1. Make sure the unit is turned **OFF**.
2. Locate the battery cover on the bottom of the unit.
3. Use a screwdriver to loosen the screw and open the battery cover.
4. Install 2 new AA (AM-3/LR6) batteries into the battery box as illustrated. (The use of new alkaline batteries is recommended for maximum performance.)
5. Replace the battery cover and tighten the screw to secure.

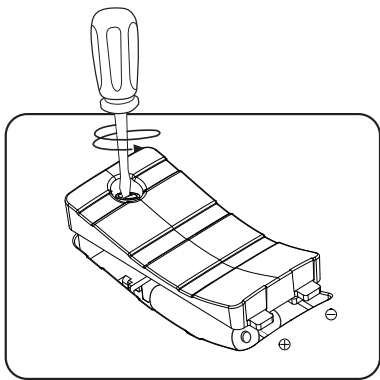

BATTERY NOTICE



- Use new alkaline batteries for maximum performance.
- Use only batteries of the same or equivalent type as recommended.
- Do not mix different types of batteries: alkaline, standard (carbon-zinc) or rechargeable, or new and used batteries.
- Do not use damaged batteries.
- Insert batteries with the correct polarity.
- Do not short-circuit the battery terminals.
- Remove exhausted batteries from the toy.
- Remove batteries during long periods of non-use.
- Do not dispose of batteries in fire.
- Do not charge non-rechargeable batteries.
- Remove rechargeable batteries from the toy before charging (if removable).
- Rechargeable batteries are only to be charged under adult supervision.

MISE EN GARDE

- Utiliser des piles alcalines neuves pour des performances maximales.
- Seules des piles du type recommandé doivent être utilisées.
- Ne pas mélanger différents types de piles ou d'accumulateurs, ne pas mélanger des piles ou des accumulateurs neufs avec des usagés.
- Ne pas utiliser des piles ou des accumulateurs endommagés.
- Mettre en place les piles ou les accumulateurs en respectant les polarités + et -.
- Ne pas mettre les bornes d'une pile ou d'un accumulateur en court-circuit (en reliant directement le + et le -).
- Enlever les piles ou les accumulateurs usagés du jouet.
- Retirer les piles ou les accumulateurs en cas de non-utilisation prolongée.
- Ne les jeter ni au feu ni dans la nature.
- Ne pas tenter de recharger des piles non rechargeables.
- Enlever les accumulateurs du jouet pour les recharger.
- Les accumulateurs ne doivent être chargés que sous la surveillance d'un adulte.

PRODUCT FEATURES

1. Off/Low/High Volume Switch

To turn the unit **On**, slide the **Off/Low/High Volume Switch** to the **Low Volume** () or the **High Volume** () position. To turn the unit **Off**, slide the **Off/Low/High Volume Switch** to the **Off** () position.

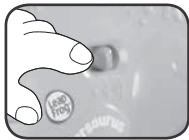

2. 26 Letter Buttons

Press any of the **26 Letter Buttons** to hear its name, sound and an example word starting with that letter plus a fun sound.



3. Light-Up Star Button

Press the **Light-Up Star Button** to hear sing-along songs including the ABC Song.

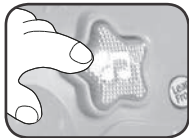

4. Tail Wheel

Spin the **Tail Wheel** to learn numbers 1-10 and play a counting song.



5. Footprint Button

Press the **Footprint Button** to turn all the letter buttons into a keyboard. Press the **Letter Buttons** to add fun sounds to a short jungle tune.

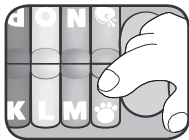

6. Dino Button

Press the **Dino Button** to hear friendly phrases from your dino friend.

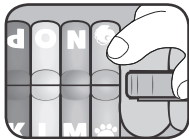

ACTIVITIES

1. Pull-Along Play

Hold onto the **Pull String** and take your dinosaur friend on a walk to hear the ABC Song or go on a pretend adventure. Watch as he wobbles along on his **Wheels** and turns his head from side to side as the **Light-Up Star Button** blinks along.



2. Sitting Play

Press the **Letter Buttons**, spin the **Tail Wheel** or press the **Light-Up Star Button** to learn about letters, numbers and listen to sing-along songs.



CARE & MAINTENANCE

1. Keep the unit clean by wiping it with a slightly damp cloth.
2. Keep the unit out of direct sunlight and away from any direct heat sources.
3. Remove the batteries when the unit is not in use for an extended period of time.
4. Do not drop the unit on a hard surface and do not expose the unit to excess moisture.

TROUBLESHOOTING

If for some reason the program/activity stops working, please follow these steps:

1. Turn the unit **OFF**.
2. Interrupt the power supply by removing the batteries.
3. Let the unit stand for a few minutes, then replace the batteries.
4. Turn the unit back **ON**. The unit will now be ready to play again.
5. If the unit still does not work, replace with an entire set of new batteries.

Environmental Phenomena

The unit may malfunction if subjected to radio-frequency interference. It should revert to normal operation when the interference stops. If not, it may become necessary to turn the power **OFF** and back **ON**, or remove and reinstall the batteries. In the unlikely event of an electrostatic discharge, the unit may malfunction and lose memory, requiring the user to reset the device by removing and reinstalling the batteries.

Impact de l'environnement

Une défaillance de fonctionnement de l'appareil peut survenir s'il est sujet à des interférences avec les fréquences radioélectriques. Le fonctionnement normal de l'appareil devrait reprendre avec l'arrêt des interférences. Si ce n'est pas le cas, il peut s'avérer nécessaire d'éteindre et rallumer l'appareil ou de retirer et réinstaller les piles. Dans l'éventualité peu probable d'une décharge électrostatique, un mauvais fonctionnement et une perte de mémoire de l'appareil peuvent se produire. L'utilisateur doit alors retirer et réinstaller les piles pour réinitialiser l'appareil.

Supplier's Declaration of Conformity

Trade Name:	LeapFrog®
Model:	6074
Product name:	Lettersaurus™
Responsible Party:	LeapFrog Enterprises, Inc.
Address:	6401 Hollis Street, Suite 100, Emeryville, CA 94608
Website:	leapfrog.com

IMPORTANT NOTE:

If the problem persists, please call our Consumer Services Department at **1-800-701-5327** in the U.S. or email support@leapfrog.com. Creating and developing LeapFrog® products is accompanied by a responsibility that we take very seriously. We make every effort to ensure the accuracy of the information, which forms the value of our products. However, errors sometimes can occur. It is important for you to know that we stand behind our products and encourage you to contact us with any problems and/or suggestions you might have. A service representative will be happy to help you.

NOTE:

This equipment has been tested and found to comply with the limits for a Class B digital device, pursuant to Part 15 of the FCC Rules. These limits are designed to provide reasonable protection against harmful interference in a residential installation. This equipment generates, uses and can radiate radio frequency energy and, if not installed and used in accordance with the instructions, may cause harmful interference to radio communications. However, there is no guarantee that interference will not occur in a particular installation. If this equipment does cause harmful interference to radio or television reception, which can be determined by turning the equipment off and on, the user is encouraged to try to correct the interference by one or more of the following measures:

- Reorient or relocate the receiving antenna.
- Increase the separation between the equipment and receiver.
- Connect the equipment into an outlet on a circuit different from that to which the receiver is connected.
- Consult the dealer or an experienced radio/TV technician for help.

THIS DEVICE COMPLIES WITH PART 15 OF THE FCC RULES. OPERATION IS SUBJECT TO THE FOLLOWING TWO CONDITIONS: (1) THIS DEVICE MAY NOT CAUSE HARMFUL INTERFERENCE, AND (2) THIS DEVICE MUST ACCEPT ANY INTERFERENCE RECEIVED, INCLUDING INTERFERENCE THAT MAY CAUSE UNDESIRE OPERATION.

CAN ICES-3 (B)/NMB-3(B)

Caution: Changes or modifications not expressly approved by the party responsible for compliance could void the user's authority to operate the equipment.

**CLASS 1
LED PRODUCT**



***Visit our website for more
information about our products,
downloads, resources and more.***

leapfrog.com

***Read our complete warranty policy online
at leapfrog.com/warranty***

LeapFrog Enterprises, Inc.,
A subsidiary of VTech Holdings Limited.
TM & © 2019 LeapFrog Enterprises, Inc.
All rights reserved.
91-003652-000 