



Quick Start Guide



Get Ready for Phonics™ Spin & Learn

We aim to reduce our environmental impact and have reduced the amount of paper used for our printed manuals. The full version of the manual is available online through the following link or by scanning the QR code.

For USA



leapfrog.com/guides

For Canada



leapfrog.ca/guides

For AUS/NZ



leapfrog.com.au/guides

Read our complete warranty policy online at
leapfrog.com/legal

INCLUDED IN THE PACKAGE

- Get Ready for Phonics™ Spin & Learn
- Quick Start Guide

WARNING

All packing materials such as tape, plastic sheets, packaging locks, removable tags, cable ties, cords and packaging screws are not part of this toy, and should be discarded for your child's safety.

NOTE

Please save this Instruction Manual as it contains important information.

ATTENTION :

Pour la sécurité de votre enfant, débarrassez-vous de tous les produits d'emballage tels que rubans adhésifs, feuilles de plastique, attaches, étiquettes, cordons et vis d'emballage. Ils ne font pas partie du jouet.

NOTE :

Il est conseillé de sauvegarder ce manuel d'utilisation car il comporte des informations importantes.

Unlock the Packaging Locks

- ① Rotate the packaging locks 90 degrees counterclockwise.
- ② Pull out the packaging locks and discard.

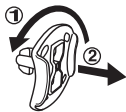

GETTING STARTED

BATTERY REMOVAL AND INSTALLATION

1. Make sure the unit is turned **Off**.
2. Locate the battery cover on the back of the unit. Use a screwdriver to loosen the screw and then open the battery cover.
3. Remove old batteries by pulling up on one end of each battery.
4. Install 3 new AA (AM-3/LR6) batteries following the diagram inside the battery box. (For best performance, alkaline batteries or fully charged Ni-MH rechargeable batteries are recommended.)
5. Replace the battery cover and tighten the screw to secure.

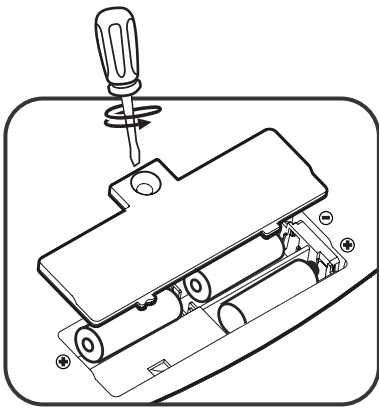



WARNING:

Adult assembly required for battery installation.
Keep batteries out of reach of children.



ATTENTION :

Les piles ou accumulateurs doivent être installés par un adulte. Tenir les piles ou accumulateurs hors de portée des enfants.

IMPORTANT: BATTERY INFORMATION

- Insert batteries with the correct polarity (+ and -).
- Do not mix old and new batteries.
- Do not mix alkaline, standard (carbon-zinc) or rechargeable batteries.
- Only batteries of the same or equivalent type as recommended are to be used.
- Do not short-circuit the supply terminals.
- Remove batteries during long periods of non-use.
- Remove exhausted batteries from the toy.
- Dispose of batteries safely. Do not dispose of batteries in fire.

RECHARGEABLE BATTERIES

- Remove rechargeable batteries (if removable) from the toy before charging.
- Rechargeable batteries are only to be charged under adult supervision.
- Do not charge non-rechargeable batteries.

CARE & MAINTENANCE

1. Keep the unit clean by wiping it with a slightly damp cloth.
2. Keep the unit out of direct sunlight and away from any direct heat sources.
3. Remove the batteries if the unit will not be in use for an extended period of time.
4. Do not drop the unit on hard surfaces and do not expose the unit to moisture or water.
5. If the unit stops working or malfunctions, install a new set of batteries.

CAUTION

Changes or modifications not expressly approved by the party responsible for compliance could void the user's authority to operate the equipment.

NOTE

This equipment has been tested and found to comply with the limits for a Class B digital device, pursuant to Part 15 of the FCC Rules. These limits are designed to provide reasonable protection against harmful interference in a residential installation. This equipment generates, uses and can radiate radio frequency energy and, if not installed and used in accordance with the instructions, may cause harmful interference to radio communications. However, there is no guarantee that interference will not occur in a particular installation. If this equipment does cause harmful interference to radio or television reception, which can be determined by turning the equipment off and on, the user is encouraged to try to correct the interference by one or more of the following measures:

- Reorient or relocate the receiving antenna.
- Increase the separation between the equipment and receiver.
- Connect the equipment into an outlet on a circuit different from that to which the receiver is connected.
- Consult the dealer or an experienced radio/TV technician for help.

IMPORTANT NOTE:

If the problem persists, please call our **Consumer Services Department** at **1-800-701-5327** in the U.S. and Canada, or email **support@leapfrog.com**. Creating and developing LeapFrog products is accompanied by a responsibility that we take very seriously. We make every effort to ensure the accuracy of the information, which forms the value of our products. However, errors sometimes can occur. It is important for you to know that we stand behind our products and encourage you to contact us with any problems and/or suggestions you might have. A service representative will be happy to help you.

Supplier's Declaration of Conformity

47 CFR § 2.1077 Compliance Information

Trade Name: LeapFrog®
Model: 6189
Product Name: Get Ready for Phonics™ Spin & Learn
Responsible Party: LeapFrog Enterprises, Inc.
Address: 2200 Powell St., Suite 500
Emeryville, CA 94608
Website: leapfrog.com

THIS DEVICE COMPLIES WITH PART 15 OF THE FCC RULES. OPERATION IS SUBJECT TO THE FOLLOWING TWO CONDITIONS: (1) THIS DEVICE MAY NOT CAUSE HARMFUL INTERFERENCE, AND (2) THIS DEVICE MUST ACCEPT ANY INTERFERENCE RECEIVED, INCLUDING INTERFERENCE THAT MAY CAUSE UNDESIRED OPERATION.