



Pound & Pop Truck™



Instruction Manual

This Manual contains important information. Please save it for future reference.

INTRODUCTION

The **Pound & Pop Truck™** is sure to be a hit with little learners! This truck features classic vehicle and pounding play with 3 fun modes of play and role play scenarios to make learning fun! Using the hammer, kids can explore colours, numbers and shapes. In colour mode pound the peg to learn different colours and watch as the side of the truck lights up reinforcing colour learning. Hank the Hound is on hand in shape mode to encourage shape learning. Listen to the shape called out, find the shape on the peg and pound that peg! Learn numbers by listening to different pretend role play scenarios. Goat wants a circle, can you pound the circle? When pounding the pegs kids develop hand eye coordination as well as learn all about cause and effect. Let's hit the road and nail learning!

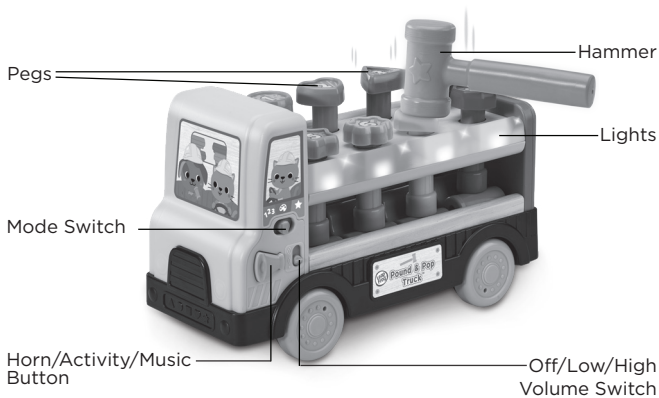

INCLUDED IN THE PACKAGE

- Pound & Pop Truck™
- Hammer
- Quick Start Guide

WARNING:

All packing materials such as tape, plastic sheets, packaging locks, removable tags, cable ties, cords and packaging screws are not part of this toy and should be discarded for your child's safety.

NOTE:

Please save this Instruction Manual as it contains important information.

Warning. Do not use close to the ear! Misuse may cause damage to hearing.

Unlock the Packaging Locks:

- ① Rotate the packaging locks 90 degrees anticlockwise.
- ② Pull out the packaging locks and discard.

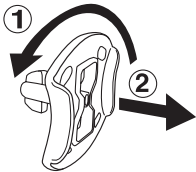

GETTING STARTED

BATTERY REMOVAL AND INSTALLATION

1. Make sure the unit is turned OFF.
2. Locate the battery cover on the back of the unit. Use a screwdriver to loosen the screw and then open the battery cover.
3. If used batteries are present, remove these batteries from the unit by pulling up on one end of each battery..
4. Install 3 new AAA (AM-4/LR03) batteries following the diagram inside the battery box. (For best performance, alkaline batteries or fully charged Ni-MH rechargeable batteries are recommended).
5. Replace the battery cover and tighten the screw to secure.

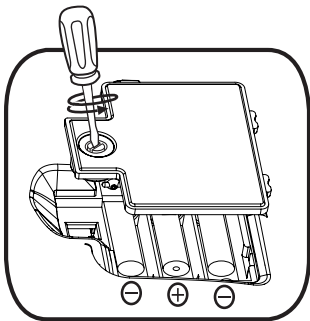

WARNING:

Adult assembly required for battery installation.
Keep batteries out of reach of children.

IMPORTANT: BATTERY INFORMATION

- Insert batteries with the correct polarity (+ and -).
- Do not mix old and new batteries.
- Do not mix alkaline, standard (carbon-zinc) or rechargeable batteries.
- Only batteries of the same or equivalent type as recommended are to be used.
- Do not short-circuit the supply terminals.
- Remove batteries during long periods of non-use.
- Remove exhausted batteries from the toy.
- Dispose of batteries safely. Do not dispose of batteries in fire.

RECHARGEABLE BATTERIES:

- Remove rechargeable batteries (if removable) from toy before charging.
- Rechargeable batteries are only to be charged under adult supervision.
- Do not charge non-rechargeable batteries.

Disposal of batteries and product



The crossed-out wheeled bin symbols on products and batteries, or on their respective packaging, indicates they must not be disposed of in domestic waste as they contain substances that can be damaging to the environment and human health.

The chemical symbols Hg, Cd or Pb, where marked, indicate that the battery contains more than the specified value of mercury (Hg), cadmium (Cd) or lead (Pb) set out in the Batteries and Accumulators Regulation.



The solid bar indicates that the product was placed on the market after 13th August, 2005.

 Please dispose of your product and batteries responsibly. In the UK, give this toy a second life by disposing of it at a small electricals collection point* so all of its materials can be recycled.

Learn more at:

www.leapfrog.co.uk/recycle

www.leapfrog.com.au/recycle

* Visit www.recyclenow.com to see a list of collection points near you.

PRODUCT FEATURES

1. Off/Low/High Volume Switch

Slide the switch to **Low**))) or **High**))) to turn the device on and select the desired volume. To turn the unit off, slide the switch to the **Off** ● position.

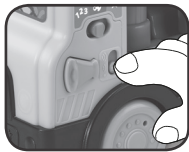

2. Horn/Activity/Music Button

Press to trigger a range of exciting responses. Hear realistic truck sounds, play fun learning activities and sing along to delightful songs!

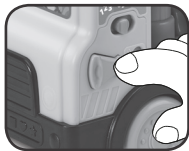

3. Mode Switch

Choose **Number**, **Colour** or **Shape** Mode.

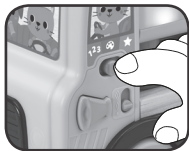

4. Hammer

Use the **hammer** to pound the pegs and practise motor skills. Little ones can also push the pegs with their hands if they like. When not in use, the hammer can be stored under the truck.

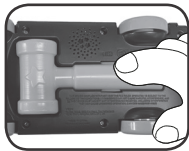

5. Pegs

Pound or push **pegs** all the way down to hear fun learning phrases.

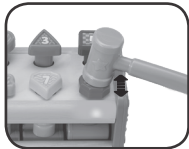

ACTIVITIES

Pressing the **Horn/Activity/Music Button** activates sounds, songs and learning games. Games include:

1. Let's Paint

Listen to the colours that Hank says, then pound them. See if you can get eight before time runs out!

2. Hammerin' Time (Numbers)

Pound the numbers as they are called out!

3. Hammerin' Time (Shapes)

Pound the shapes as they are called out!

4. Speed Pounding

Pound as many pegs as you can before the music stops!

5. Light the Lights

Pound all of the pegs to turn on all of the lights.

6. Fix the Truck

Pound any peg to rev and fix the engine. Keep pounding pegs until the truck starts.

7. Customer Orders

Duck, Goat or Pig need your help to fulfil their orders. Pound the correct peg to help them.

8. Deliveries

Pound any peg to complete a delivery for one of the animal customers.

SONG LYRICS

It's Hammerin' Time!

Start the truck, drive it around!
Find a peg and give it a pound!
It's Hammerin' Time!

Wheels the Cat and Hank the Hound

I'm Wheels the Cat!
And I'm Hank the Hound.
I like to drive,
And I'm from the pound!
Wherever we go,
We've got shapes in tow.
Woof woof!
Meow!
Engine revs and away we go!

CARE & MAINTENANCE

1. Keep the unit clean by wiping it with a slightly damp cloth.
2. Keep the unit out of direct sunlight and away from any direct heat sources.
3. Remove the batteries if the unit will not be in use for an extended period of time.
4. Do not drop the unit on hard surfaces and do not expose the unit to moisture or water.
5. Try to change the batteries for new ones if the toy is not working properly.

TROUBLESHOOTING

If for some reason the unit stops working or malfunctions, please follow these steps:

1. Turn the unit **Off**.
2. Interrupt the power supply by removing the batteries.
3. Let the unit stand for a few minutes, then replace the batteries.
4. Turn the unit back **On**. The unit should now be ready to play with again.
5. If the unit still does not work, install a brand new set of batteries.

Environmental phenomena

The unit may malfunction if subjected to radio-frequency interference. It should revert to normal operation when the interference stops. If not, it may become necessary to turn the power **OFF** and back **ON**, or remove and reinstall the batteries. In the unlikely event of an electrostatic discharge, the unit may malfunction and lose memory, requiring the user to reset the device by removing and reinstalling the batteries.

CONSUMER SERVICES

Creating and developing **LeapFrog®** products is accompanied by a responsibility that we at **LeapFrog®** take very seriously. We make every effort to ensure the accuracy of the information, which forms the value of our products. However, errors sometimes can occur. It is important for you to know that we stand behind our products and encourage you to call our Consumer Services Department with any problems and/or suggestions that you might have. A service representative will be happy to help you.

UK Customers:

Phone: 01702 200244 (from UK) or +44 1702 200244 (outside UK)

Website: www.leapfrog.co.uk/support

Australian Customers:

Phone: 1800 862 155

Website: support.leapfrog.com.au

NZ Customers:

Phone: 0800 400 785

Website: support.leapfrog.com.au

PRODUCT WARRANTY/ CONSUMER GUARANTEES

UK Customers:

Read our complete warranty policy online at leapfrog.com/warranty.

Australian Customers:

VTECH ELECTRONICS (AUSTRALIA) PTY LIMITED -
CONSUMER GUARANTEES

Under the Australian Consumer Law, a number of consumer guarantees apply to goods and services supplied by VTech Electronics (Australia) Pty Limited. Please refer to leapfrog.com/en-au/legal/warranty for further information.



***Visit our website for more
information about our products,
downloads, resources and more.***

leapfrog.com

LeapFrog Enterprises, Inc.
A subsidiary of VTech Holdings Limited.
TM & © 2024 LeapFrog Enterprises, Inc.
All rights reserved.
IM-619500-001
Version:0