



My First STEAM Tablet™



Instruction Manual

This manual contains important information. Please save it for future reference.

INTRODUCTION

Thank you for purchasing **My First STEAM Tablet™**! Steam ahead into a world of learning as you investigate science concepts with Dr. Frankensteam and his buddy Steam-Bot!

Along the way, explore technology, engineering, letter names, letter sounds, numbers, counting and more!

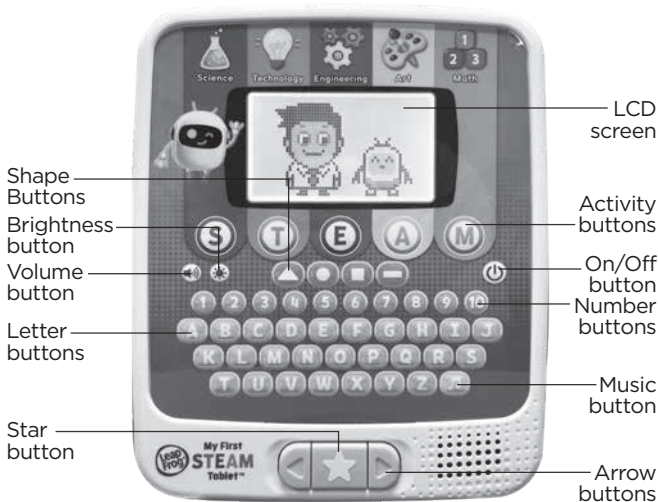

INCLUDED IN THE PACKAGE

- My First STEAM Tablet™
- Quick Start Guide

WARNING

All packing materials such as tape, plastic sheets, packaging locks, removable tags, cable ties and packaging screws are not part of this toy, and should be discarded for your child's safety.

NOTE

Please save this Instruction Manual as it contains important information.

ATTENTION

Pour la sécurité de votre enfant, débarrassez-vous de tous les produits d'emballage tels que rubans adhésifs, feuilles de plastique, attaches, étiquettes, cordons et vis d'emballage. Ils ne font pas partie du jouet.

NOTE

Il est conseillé de sauvegarder ce manuel d'instructions car il comporte des informations importantes.

Unlock the Packaging Locks

- ① Rotate the packaging locks 90 degrees counterclockwise.
- ② Pull out the packaging locks and discard.

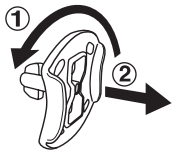

GETTING STARTED

BATTERY REMOVAL AND INSTALLATION

1. Make sure the unit is turned **Off**.
2. Find the battery covers located on the bottom. Use a screwdriver to loosen the screws, and then open the battery covers.
3. Remove old batteries by pulling up on one end of each battery.
4. Install 3 new AA (AM-3/LR6) batteries following the diagram inside the battery box. (For best performance, alkaline batteries or fully charged Ni-MH rechargeable batteries are recommended.)
5. Replace the battery covers and tighten the screws to secure.

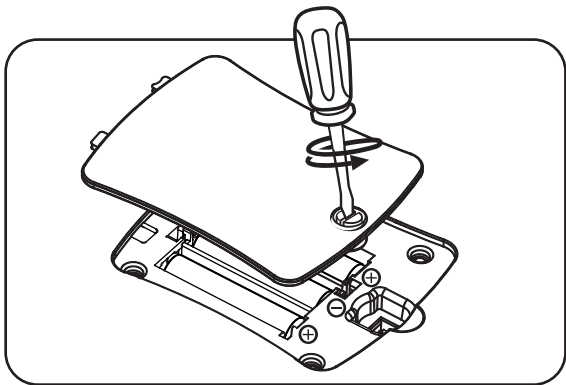



WARNING:

Adult assembly required for battery installation.
Keep batteries out of reach of children.



ATTENTION :

Les piles ou accumulateurs doivent être installés par un adulte. Tenir les piles ou accumulateurs hors de portée des enfants.

IMPORTANT: BATTERY INFORMATION

- Insert batteries with the correct polarity (+ and -).
- Do not mix old and new batteries.
- Do not mix alkaline, standard (carbon-zinc) or rechargeable batteries.
- Only batteries of the same or equivalent type as recommended are to be used.
- Do not short-circuit the supply terminals.
- Remove batteries during long periods of non-use.
- Remove exhausted batteries from the toy.
- Dispose of batteries safely. Do not dispose of batteries in fire.

RECHARGEABLE BATTERIES

- Remove rechargeable batteries (if removable) from the toy before charging.
- Rechargeable batteries are only to be charged under adult supervision.
- Do not charge non-rechargeable batteries.

PRODUCT FEATURES

1. On/Off Button

Press the **On/Off Button** to turn the toy on and off.



2. Brightness Button

Press to access the screen's brightness settings.

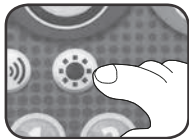

3. Volume Button

Press to access the volume settings.



4. Activity Buttons

Press to choose a fun learning activity.



5. LCD Screen

The **LCD Screen** displays the toy's animations.



6. Shape Buttons

Press the **Shape Buttons** to see shape animations and hear silly phrases.



7. Number Buttons

Press the **Number Buttons** to see number animations and hear funny phrases.



8. Letter Buttons

Press the **Letter Buttons** to see letter animations and hear humorous phrases.



9. Music Button

Press the **Music Button** to jam along to learning songs.



10. Star Button

The **Star Button** is used as an action button in certain activities. When no activity is in progress, it triggers fun letter and number animations.



11. Arrow Buttons

The **Arrow Buttons** are used to choose answers in certain activities. When no activity is in progress, they also trigger fun letter and number animations.



12. Automatic Shut-Off

To preserve battery life, the **My First STEAM Tablet™** will automatically shut off after approximately 50-70 seconds without input. The unit can be turned on again by pressing the On/Off Button.

ACTIVITIES

1. Science

Select a seed, dig a hole, water it, add sun and watch it grow. Practice your counting along the way!



2. Technology

Help Dr. Frankensteam find his missing lab equipment by identifying 16 different machines and devices. Two different devices will be shown at a time and he will describe the device he is looking for. Press the arrow button to highlight one and then press the star button to select it. When you select the correct answer, a silly animation will show the device in action.



3. Engineering

Build machines using shapes. Press the shape buttons to fill in the missing pieces. Finding three shapes completes the puzzle and triggers a fun animation.



4. Art

Get creative and use shapes to design unique pictures. Press a shape button and watch them pop into the images. Keep adding shapes until the picture mosaic is complete.



5. Math

Help recycle cans, dig for dinosaur bones, repair a robot and fill test tubes. Press the star button to perform each of the actions as Dr. Frankensteam counts. Then, complete the activity by pressing the number button that matches the correct amount of items on the screen.



CARE & MAINTENANCE

1. Keep the unit clean by wiping it with a slightly damp cloth.
2. Keep the unit out of direct sunlight and away from any direct heat sources.
3. Remove the batteries if the unit will not be in use for an extended period of time.
4. Do not drop the unit on hard surfaces and do not expose the unit to moisture or water.

TROUBLESHOOTING

If for some reason the unit stops working or malfunctions, please follow these steps:

1. Turn the unit **Off**.
2. Interrupt the power supply by removing the batteries.
3. Let the unit stand for a few minutes, then replace the batteries.
4. Turn the unit **On**. The unit should now be ready to use again.
5. If the unit still does not work, install a new set of batteries.

Environmental Phenomena

The unit may malfunction if subjected to radio-frequency interference. It should revert to normal operation when the interference stops. If not, it may become necessary to turn the power **off** and back **on**, or remove and reinstall the batteries. In the unlikely event of an electrostatic discharge, the unit may malfunction and lose memory, requiring the user to reset the device by removing and reinstalling the batteries.

Impact de l'environnement

Une défaillance de fonctionnement de l'appareil peut survenir s'il est sujet à des interférences avec les fréquences radioélectriques. Le fonctionnement normal de l'appareil devrait reprendre avec l'arrêt des interférences. Si ce n'est pas le cas, il peut s'avérer nécessaire d'éteindre et rallumer l'appareil ou de retirer et réinstaller les piles. Dans l'éventualité peu probable d'une décharge électrostatique, un mauvais fonctionnement et une perte de mémoire de l'appareil peuvent se produire. L'utilisateur doit alors retirer et réinstaller les piles pour réinitialiser l'appareil.

NOTE

This equipment has been tested and found to comply with the limits for a Class B digital device, pursuant to Part 15 of the FCC Rules. These limits are designed to provide reasonable protection against harmful interference in a residential installation. This equipment generates, uses and can radiate radio frequency energy and, if not installed and used in accordance with the instructions, may cause harmful interference to radio communications. However, there is no guarantee that interference will not occur in a particular installation. If this equipment does cause harmful interference to radio or television reception, which can be determined by turning the equipment off and on, the user is encouraged to try to correct the interference by one or more of the following measures:

- Reorient or relocate the receiving antenna.
- Increase the separation between the equipment and receiver.
- Connect the equipment into an outlet on a circuit different from that to which the receiver is connected.
- Consult the dealer or an experienced radio/TV technician for help.

CAUTION

Changes or modifications not expressly approved by the party responsible for compliance could void the user's authority to operate the equipment.

IMPORTANT NOTE:

If the problem persists, please call our **Consumer Services Department** at **1-800-701-5327** in the U.S. and Canada, or email **support@leapfrog.com**. Creating and developing LeapFrog products is accompanied by a responsibility that we take very seriously. We make every effort to ensure the accuracy of the information, which forms the value of our products. However, errors sometimes can occur. It is important for you to know that we stand behind our products and encourage you to contact us with any problems and/or suggestions you might have. A service representative will be happy to help you.

Supplier's Declaration of Conformity

47 CFR § 2.1077 Compliance Information

Trade Name: LeapFrog®
Model: 6204
Product Name: My First STEAM Tablet™
Responsible Party: LeapFrog Enterprises, Inc.
Address: 2200 Powell St., Suite 500
Emeryville, CA 94608
Website: leapfrog.com

THIS DEVICE COMPLIES WITH PART 15 OF THE FCC RULES. OPERATION IS SUBJECT TO THE FOLLOWING TWO CONDITIONS: (1) THIS DEVICE MAY NOT CAUSE HARMFUL INTERFERENCE, AND (2) THIS DEVICE MUST ACCEPT ANY INTERFERENCE RECEIVED, INCLUDING INTERFERENCE THAT MAY CAUSE UNDESIRE OPERATION.



**Visit our website for more
information about our products,
downloads, resources and more.**

leapfrog.com

leapfrog.ca

Read our complete warranty policy online at

leapfrog.com/legal

LeapFrog Enterprises, Inc.,
A subsidiary of VTech Holdings Limited.
© 2024 LeapFrog Enterprises, Inc.
All rights reserved.
IM-620400-000
Version:0